

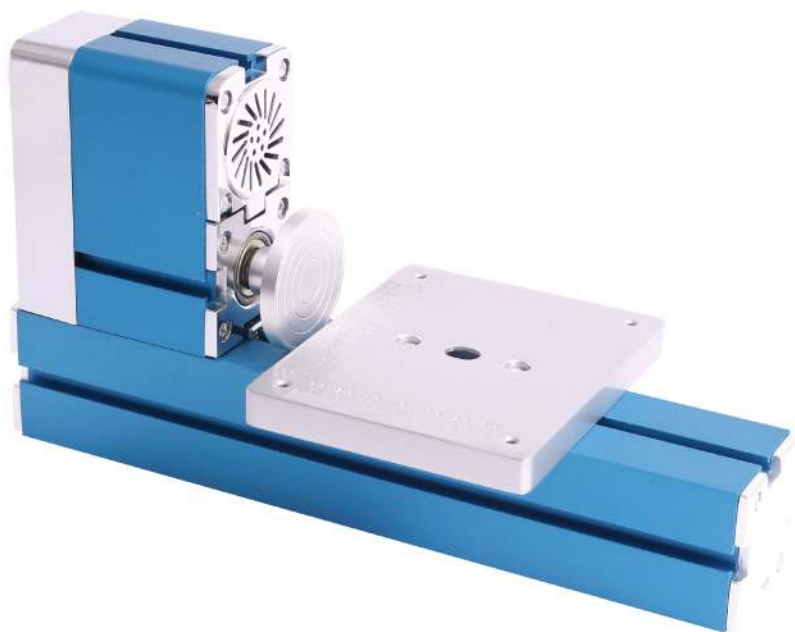

# 万能金属机床系列说明书

MINI METAL MACHINE  
USER MANUAL



W106MA/MB/MC  
万能金属磨床  
Metal Sanding Machine

感谢您选购先导万能机床，先导万能机床是针对青少年和模型爱好者设计的一种微型机械加工设备。本产品是一种益智、创客工具类产品。它有助于培养和提高操作者的动手能力、独立思考能力，助力有理想的创客实现自己的想法。

Thank you for choosing XENDOLL multipurpose machines, which are designed for teenagers and DIY hobbyist. It not only helps to cultivate, improve the operational ability and independent thinking, but also inspire operators to achieve their dreams.

## 致客户/用户 To Customers

为了保障您的安全和健康，请在使用机器前，仔细阅读本说明书。本手册包含机床图解、操作方法、维护清洁、故障排查等，正确的方法会使你的操作更顺畅。

Please read the instruction carefully before using the product. It shows you the whole procedures of operation, maintenance, inspection and cleaning. Further cautions and warning can be found on each machine's operation instruction. Proper operation will make your experience more easier.

## 安全注意事项 General Caution And Warning

- 保持工作区域干净，不要在脏乱、潮湿的环境下工作。为了您的健康，工作室应通风良好；

Keep the working area clean and dry. Do not work under dirty and wet environment. We highly recommend working in a dust free environment with sufficient airing.

- 少年儿童需在成人陪同下使用；  
Children use the machine under supervision of adults.

- 不使用时机器应储存在孩子无法自由取用的地方；  
Keep the machine out of reach of children.

- 操作时应佩戴好护目镜，保护您的眼睛；  
Always wear goggle to protect your eyes when operating the machine.
- 露在外面的衣服（衣袖）或头发应束好，不可靠近旋转物件，以免卷入弄伤；  
Keep your hair and clothing away from the moving parts.
- 机器运转时如有异响应立即停机检查，查明原因并修复后再开机继续使用；  
Stop the machine immediately when anomalous sound is heard, use it after the issue was found and fixed.
- 经常检查部件是否有损坏，若有损坏应立即替换或维修被损坏或磨损部分。由于先导机床一些零部件有特殊设计，建议使用原厂零部件，如因使用非原厂零部件而引起不良后果，我司不予负责；  
Always check the machine before operation , shift or replace the worn parts if required. As some of the components are designed specially for the machine, you are advised to use our components avoiding injury and to extend the life span of your machine.
- 保持工作室的清洁，油脂、余料及其他杂物需及时清理，工作室不宜储存易燃、易爆及化学用品；  
Keep away from chemicals and explosives.
- 本手册不包括全部可能发生的情况和操作，了解常识和小心最安全；  
Our manual has not covered all the conditions that you may confront. Please always operates with caution.
- 由于产品升级换代，图片可能与实物有差别，请以实物为准，敬请留意！  
Due to irregular upgrading of product, the image/pictures shown in the manual are for reference only.

## 1.技术参数 Technical Parameter

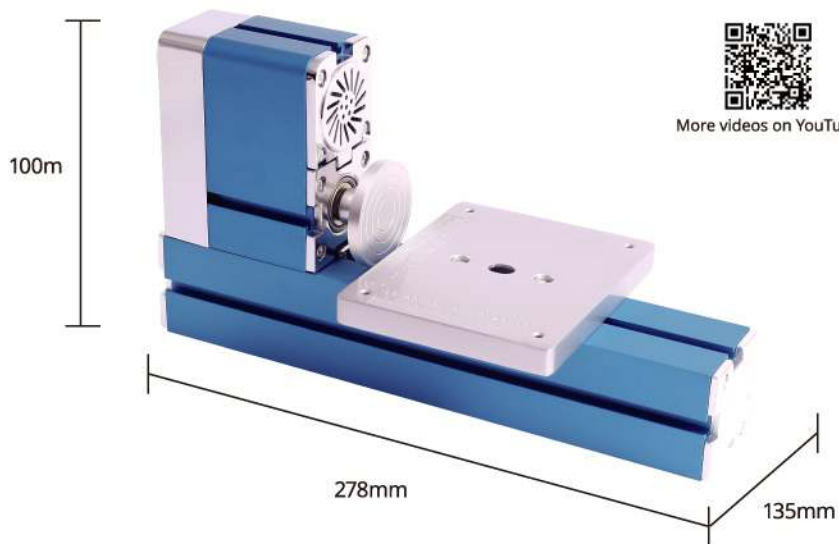

输入电压 Input Voltage	/	AC 100V-240V 50/60HZ
输出电压 Output Voltage	/	DC 12V
电流 Direct Current	/	2A
电机转速 Motor Speed	r/min	20000±15%
主轴转速 Spindle Speed	r/min	3000±15%
中心高 Center Height	mm	25
轮盘直径 Panel Diameter	mm	φ49
包装尺寸 Packing Size	mm	330x210x240

## 2. 部件清单 Part List



W003

主轴箱 Headstock



W051

砂轮罩 Wheel Guard



W011

长机座 Machine Bed, Long



W010

轮盘 Sanding Panel



W053

砂轮 Grinding Wheel



W004

磨床工作台 Working Table



W005

连接块 Connection Piece



W021

皮带轮罩 Drive Belt Cover

### 3.随机配件清单 Accessories



型号 S.N	部件名称 Parts	规格 Spec.
W002	单头开关电源 Power Adapter	12V 2A
W055	薄款双头扳手 Open End Wrench	/
W028	单孔槽螺母 Slot Nut	/
W038	内六角扳手 HEX Wrench	S=2X2
W046/W047	自粘砂纸 Sanding Paper	φ48 120#、φ48 400#
W051/W052	砂轮罩和连接块 Wheel Guard	/
W053	砂轮组合 Grinding Wheel	/
W082	十字盘头螺钉 Screw	M4X10
W029	双孔槽螺母 Slot Nut-double Hole	/
W095	十字大扁头机丝螺钉 Screw	M4X16
W057	十字小号螺丝刀 Screwdriver	L=128X3.0
W058	十字中号螺丝刀 Screwdriver	L=190X4.0
W096	围裙 Apron	/
W097	护目镜 Goggle	/

## 4. 安装图 Installation Diagram

### Step 01.

马达主轴箱安装。

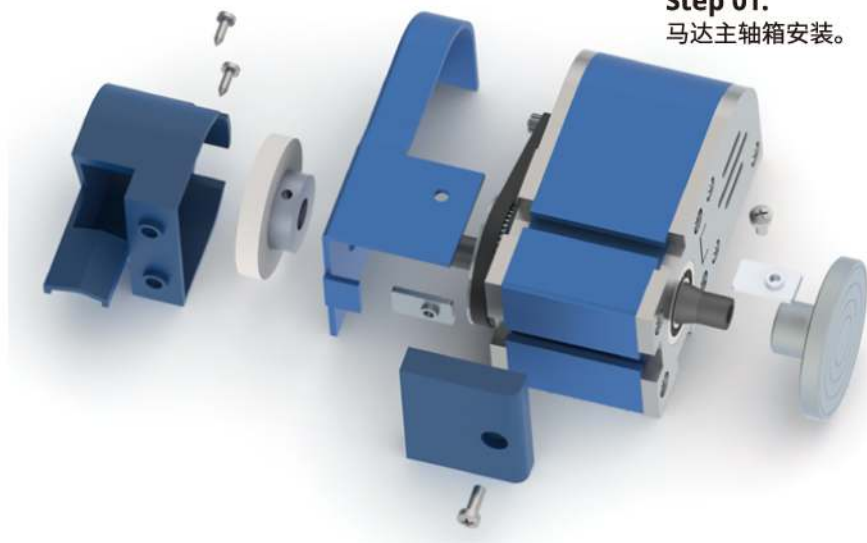

### Step 02.

主轴箱、长机座  
与工作台连接安装。

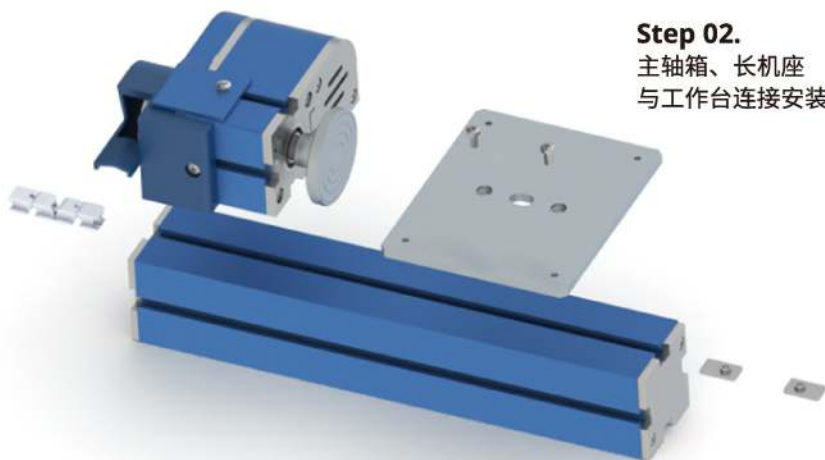

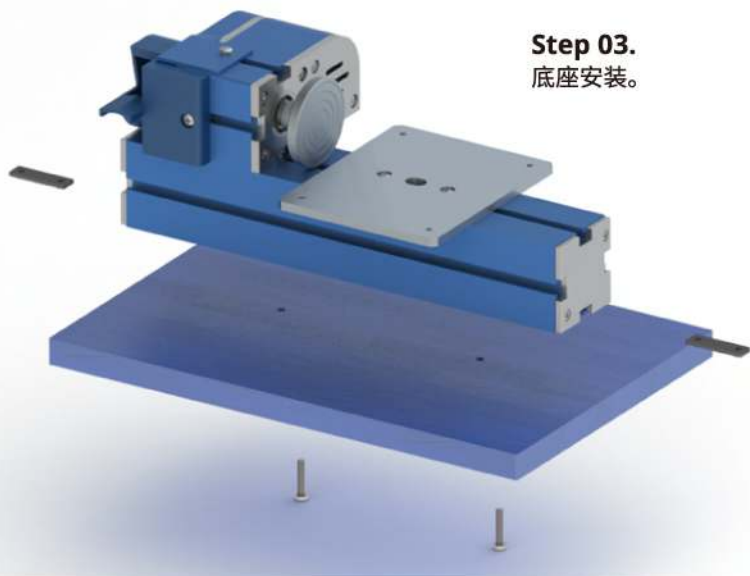
**Step 03.**  
底座安装。**5.使用须知 General Operation Cautions**

- 使用机床前，请检查机器零部件是否接触良好，防止运输过程中可能造成部分零件松散。  
Please make sure all the parts of machine are tightened before all the operations.
- 使用前，将圆形砂纸平整贴在轮盘上。检查轮盘、砂轮及砂轮罩，确保连接牢固。  
Stick the sanding paper on the sanding panel.
- 调整工作台与轮盘砂纸的距离，间隔距离约5mm。  
Adjust the distance between working table and sanding panel, the interval distance should be around 5mm.
- 工作时请勿将砂轮罩拆下。  
Do not remove the wheel guard while operating.



- 磨刀具请使用砂轮，打磨工件请使用砂纸。使用砂轮磨刀具时请对准砂轮中心线，不要偏离中心线太远。使用砂纸打磨工件时，工件移动方向与砂纸旋转方向相反。  
Grinding wheel is for tool sharpening, make sure align the tool tip to the grinding wheel as much as possible.
- 加工时出现噪声过大或皮带松脱时，请关闭电源后调整皮带松紧度。  
Turn off the machine for drive belt adjustment if the machine is too chatters.
- 加工时，请勿用手触碰旋转部件；避免衣服和头发接触旋转部件；使用时应佩戴护目镜。  
Never touch the rotating parts. Keep hair and cloths away from the machine. Always wear the goggle while working.
- 使用时，因阻力过大，导致主轴不转或速度明显减慢时，请在三秒内移开阻力或切断电源，以免烧毁电源，查明原因并解决问题，再启动机器。  
If it is too loud or the belt is loosened, please turn off the power and adjust the tightness of the belt .Choose the feed rate and depth of each layer properly according to your workpiece.
- 使用完毕，先关闭开关，再拔出电源。  
Always turn off the machine before unplugging the power cord.

## 6. 砂轮罩安装图 Install The Grinding Wheels

使用十字螺丝刀把皮带轮盖拆卸下来。

Take off the cover with screwdriver.



把砂轮安装在主轴上并用内六角扳手拧紧砂轮上的回紧定螺丝。

Install the grinding wheels on the bearing and tighten it.



在主轴箱底部放入单孔槽，并把砂轮罩放入。  
Place the slot nut and protection cap.



使用十字盘头螺钉 M4X10 锁紧皮带轮罩。  
Lock the protection cap with screw.

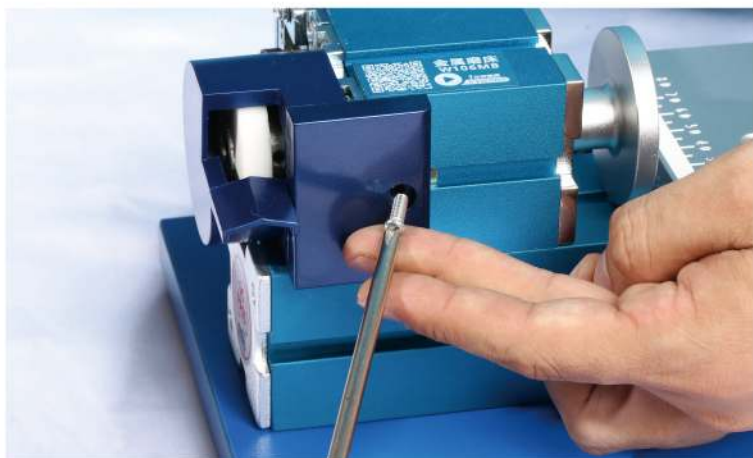

## 7. 打磨的正确方法 Correct Method Of Grinding

打磨材料的时候，把材料放于磨床工作台上，然后把需要打磨的位置靠近轮盘，根据需要打磨的形状进行角度调节。

Put the material on the working table and approach the sanding panel slowly. Change the direction as you need.



打磨凿刀的时候，右手抓住凿刀手柄，左手扶住凿刀，让凿刀靠近砂轮，让凿刀的刀刃逆着砂轮转动的方向打磨凿刀（如图）。

Hold the tool with hands, make sure align the tool tip to the grinding wheel as much as possible.

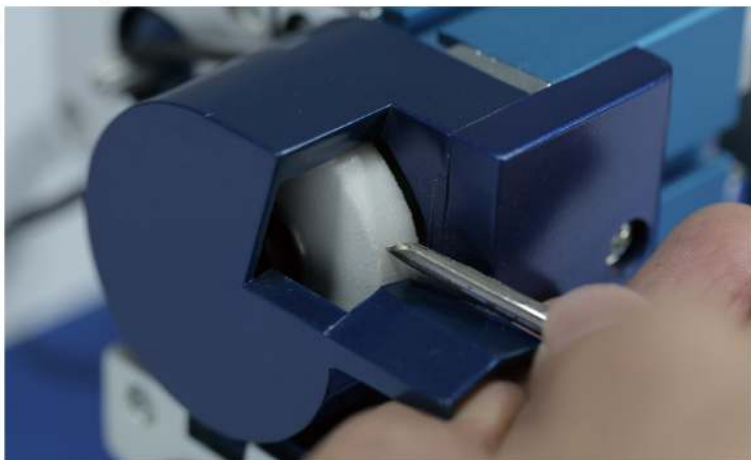

## 8. 皮带松紧调节方法 How To Adjust The Belt

W106MA系列主轴箱：

用十字螺丝刀调节主轴箱上的皮带调节螺钉，朝顺时针方向拧为拉紧皮带，朝逆时针方向拧为调松皮带。调整螺钉后请将螺钉头朝下压一下以消除螺钉虚位。  
Use the Phillips screwdriver to adjust the screw on the headstock. Clockwise tighten and counter clockwise loosen (As shown in the figure).

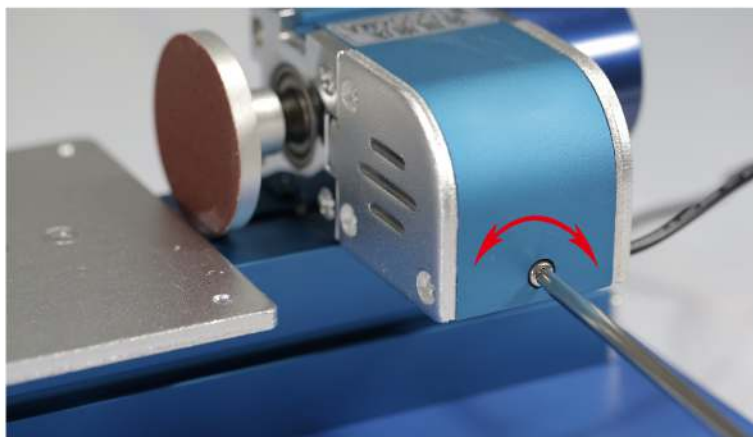

用手压下皮带，皮带压下量为3至5mm时皮带松紧度适宜。

To check the tightness of the drive belt as shown in the figure.

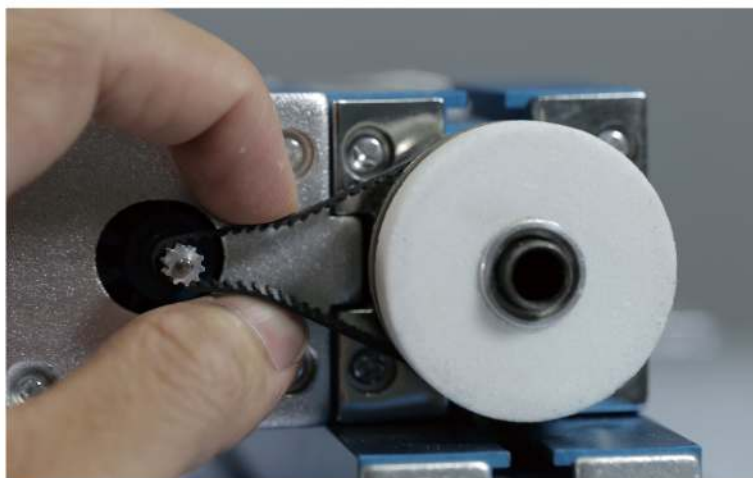

## W106MB/MC系列主轴箱:

松开皮带轮罩  
Take off the  
belt cover



松开固定块上  
两个螺丝  
Loosen the  
screw



调松紧皮带

Adjust the screw on the top, clockwise tighten and counter clockwise loosen  
(As shown in the figure).

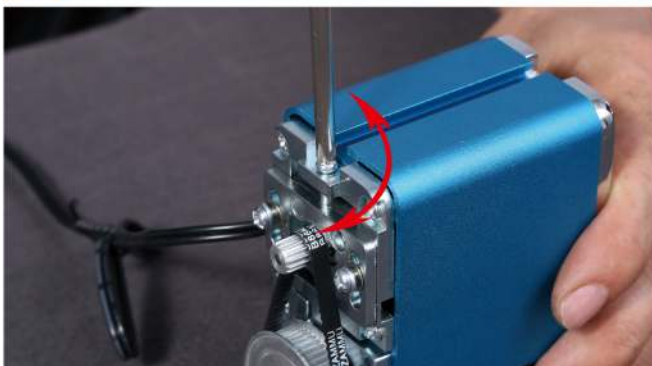

用手压下皮带，皮带压下量为3至5mm时皮带松紧度适宜，然后拧紧电机固定块上的两颗螺丝后把皮带轮罩安装上即可。

To check the tightness of the drive belt as shown in the figure, retighten the screw and put the belt cover on.



## 9. 连接块的摆放 How To Assemble The Connection Pieces

连接块间相互错开放置（如图所示），螺丝头朝外侧。安装时，连接块的厚截面面向上，它的朝向（上下朝向）须朝向需要移动部件一侧。

Put each piece contrary to the others (as shown in the figure), the head of the screw faces outward. Each piece's inclined plane faces inward with the other one.





## 10. 常见故障处理 Possible Solutions

故障现象 Problems	原因分析 Possible cause	故障现象 Solution
通电后主轴不转 Headstock is not working	电源适配器无输出 Adapter is broken	更换电源 Replace adapter
	主轴卡滞 Spindle is broken	更换主轴轴承 Bearing loosen or worn
	皮带脱开 Driver belt is off the motor	安装皮带并调整松紧 Reload the belt and adjusted
运转噪声过大 Abnormal sounds and noise	各部件连接松动 Loose parts	紧固各部件 Tighten the parts between others
	皮带过松/过紧 The belt is too loose / too tight	调整皮带松紧度 Adjust the tightness of the belt
打磨不平顺 Sanding issue	砂纸粘贴不平整 Sanding paper not stick well	重新粘贴平整 Replace sanding paper
	砂纸正常磨损 Sanding paper dull	更换砂纸 Replace the sanding paper

# 保修卡

## 尊敬的用户：

感谢您购买并用本产品，为了使我们的服务让您满意，购买后请认真阅读此保修卡并妥善保存。

一、此保修卡为质保凭证，必须加盖厂家或经销商的印章才有效。

二、免费保修期为一年，自保修卡上注明日期开始计算。

丝杆	轴承	主轴箱
大小滑块	开关电源	长机座
短机座	顶尾座	中间块

质量保证期满后，对设备进行维修，只收取成本费用。最短的时间内完成。

## 三、下列范围不属于免费保修服务范围：

我们的保修承诺只适用于最初的购买客户，保修期内正常使用情况下所引起的损坏，不包含消耗性的附件或任何由于使用不当、粗心操作、改造引起的损坏。

- 1、超过保修期的机器
- 2、未按产品使用说明的要求使用，维护、保管而造成损坏的。
- 3、自行改装过机器。
- 4、因不可抗力造成损坏的。

## 四、如何得到服务

当您需要维修服务时，将机床或部件打包退还我司或保修点。同时出示当时的购买凭证。我们会在最短的时间内完成。

## 相关信息填写表

若您是通过代理商购买产品，请提供该代理商的正确信息，多谢合作！

产品名称： \_\_\_\_\_ 销售日期： \_\_\_\_\_

经销商名称： \_\_\_\_\_ 经销商电话： \_\_\_\_\_

故障现象： \_\_\_\_\_

导致原因： \_\_\_\_\_

用户单位： \_\_\_\_\_ 姓名： \_\_\_\_\_ 联系电话： \_\_\_\_\_

收货地址： \_\_\_\_\_

# Warranty Card

## Dear Customer:

Thank you for choosing our products. Please read carefully and keep this warranty card safely.

**1. This warranty card must be stamped with seal of the manufacturer or dealer.**

**2. List of parts under 1 year warranty.**

Lead screw	Bearing	Headstock
Slide	Power switch	Machine bed, long
Machine bed, short	Tailstock	Intermediate connection piece

Charges will be applied for repairs and maintenance after expiry date.

**3. This warranty excludes and does not cover defect, malfunctions or failures which were caused by repairs by persons not authorized by us, use of parts or accessories not authorized by us, mishandling, improper installation, modifications, or damage to the machine while in your possession, or unreasonable use.**

**4. Please pack the machine properly with the warranty card and mail it to our after-sale service department.**

---

## Customer Registration Form

If you purchased our products through an agent, please provide the information of the agency. Thank you for your cooperation!

**Product Model Number / Name:** \_\_\_\_\_

**Purchase Date:** \_\_\_\_\_

**Name of agency:** \_\_\_\_\_

**Phone No. :** \_\_\_\_\_

**Malfunction:** \_\_\_\_\_

**Customer Name:** \_\_\_\_\_

**Customer Phone No. :** \_\_\_\_\_

**Customer Address:** \_\_\_\_\_



地址：广东省佛山市顺德区国家高新开发区(容桂高黎)科苑一路3号

电话：0757-28386038 售后电话：18928655227

邮编：528305

网址：www.xendoll.com 邮箱：info@xendoll.com

Foshan Xendoll Intelligent Technology Co., Ltd.

Address: No.3 Keyuan Road, (Ronggui Gaoli), National High Tech Development Zone,  
Shunde District, Foshan City, Guangdong Province, China

Phone: 0757-28386038 Post Code: 528305

Website: www.xendoll.com E-mail: info@xendoll.com



手机版网站



微信公众号



售后服务